

***MESA/BOOGIE***

***BIGBLOCK750™***

***Owner's Manual***

## *Greetings from the Home of Tone*

*Congratulations on your choice of the Big Block 750 as your Bass amplifier and welcome to the MESA/Boogie family! As a discriminating player you probably know that you have purchased the most comprehensive instrument for amplifying Bass that is available. What you might not realize is that this entitles you to all the experience, resources and commitment our twenty-five years of service to musicians world wide has to offer. Our responsibility is to help you sound great! So, if at any time you feel you need help or direction, we are here for you...a phone call away.*

# PRECAUTIONS & WARNINGS

*Your MESA/Boogie Amplifier is a professional instrument. Please treat it with respect and operate it properly.*

## USE COMMON SENSE AND ALWAYS OBSERVE THESE PRECAUTIONS:

**WARNING:** Vacuum tube amplifiers generate heat. To insure proper ventilation always make certain there is at least four inches (100mm) of space behind the rear of the amplifier cabinet. Keep away from curtains or any flammable objects.

**WARNING:** Do not block any ventilation openings on the rear or top of the amplifier. Do not impede ventilation by placing objects on top of the amplifier which extend past the rear edge of its cabinet.

**WARNING:** Do not expose the amplifier to rain, moisture, dripping or splashing water. Do not place objects filled with liquids on or nearby the amplifier.

**WARNING:** Always make certain proper load is connected before operating the amplifier. Failure to do so could pose a shock hazard and may result in damage to the amplifier.

Do not expose amplifier to direct sunlight or extremely high temperatures.

Always insure that amplifier is properly grounded. Always unplug AC power cord before changing fuse or any tubes. When replacing fuse, use only same type and rating.

Avoid direct contact with heated tubes. Keep amplifier away from children.

Be sure to connect to an AC power supply that meets the power supply specifications listed on the rear of the unit. Remove the power plug from the AC mains socket if the unit is to be stored for an extended period of time. If there is any danger of lightning occurring nearby, remove the power plug from the wall socket in advance.

To avoid damaging your speakers and other playback equipment, turn off the power of all related equipment before making the connections.

Do not use excessive force in handling control buttons, switches and controls. Do not use solvents such as benzene or paint thinner to clean the unit. Wipe off the exterior with soft cloth.

**YOUR AMPLIFIER IS LOUD! EXPOSURE TO HIGH SOUND VOLUMES MAY CAUSE PERMANENT HEARING DAMAGE !**

**No user serviceable parts inside.** Refer service to qualified personnel. Always unplug AC power before removing chassis.

**EXPORT MODELS:** Always insure that unit is wired for proper voltage. Make certain grounding conforms with local standards.

**WARNING:** EU: permission from the Supply Authority is needed before connection.

**READ AND FOLLOW INSTRUCTIONS OF PROPER USAGE.**

# ***BIG-BLOCK750***<sup>TM</sup>

## Table of Contents

Precautions _____	0
Overview _____	1/2

### **FRONT PANEL:**

INSTRUMENT INPUT _____	3
TUNER _____	3

#### CONTROLS:

OVERDRIVE _____	3/4
GAIN _____	4
BASS _____	4/5
PASSIVE MID _____	5
ACTIVE MID _____	5
FREQUENCY _____	6
TREBLE _____	6
MASTER _____	6
O.D.MASTER _____	7
POWER SWITCH _____	7

### **REAR PANEL:**

FUSE _____	8
A.C. RECEPTACLE _____	8
GROUND LIFT /POST & PRE / DIRECT OUT: _____	8/9
EFFECTS LOOP: Send & Return _____	9
FOOTSWITCH _____	9
TUNER _____	10
SLAVE _____	10
SPEAKERS _____	10
FACTORY SAMPLE SETTINGS _____	11
PERSONAL SETTINGS PAGE _____	12
DIAGNOSING PRE-AMP TUBE PROBLEMS _____	13
PARTS SHEET _____	14

# BIG-BLOCK 750™

## Operating Instructions

### Overview:

Congratulations on your choice of the *M-PULSE BIG BLOCK 750* as your amplifier and welcome to the *MESA/Boogie* Family! First we would like to thank you for choosing us as your amplifier company. This is something we never take for granted and you will come to find that we are here to help you sound your best should you ever need help. We feel confident that your new amplifier will bring you many years of rewarding inspiration and create for you a newfound freedom to express through your music.

This mighty powerhouse joins the innovative band of *M-PULSE* hybrid bass amplifiers as the heavyweight king of headroom with its urgent big venue tone. It represents the ultimate marriage of simplicity and versatility and will surprise you daily with its fundamental musicality and tone.

The *BLOCK* stands firmly on the same soulful sounding ground as all *M-PULSE* amplifiers, with architecture based on our 30 years of all-tube preamp experience and *Simul State™ Power* - which utilizes a tube driver stage feeding a bank of custom designed mosfet output devices. This design seamlessly integrates the best sonic qualities of old-world tube circuitry and modern high power mosfet technology to arrive at a stunning blend that is both musical and powerful. In the *BIG 750's* case, that is doubly true. This monolith of tone harnesses not one, but two power blocks, putting at your immediate disposal ridiculous amounts of transient handling current produced by the 20 mosfet devices. This means when you want to say something with your instrument, your voice will be heard with accuracy, both harmonically and in the time domain. Every bassist knows how important that is!

### FRONT VIEW: Big Block 750

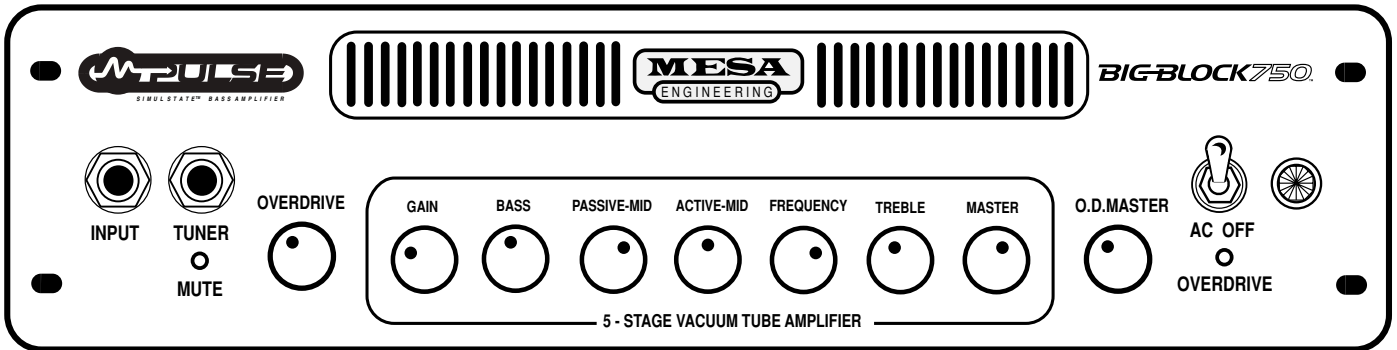

### REAR VIEW: Big Block 750

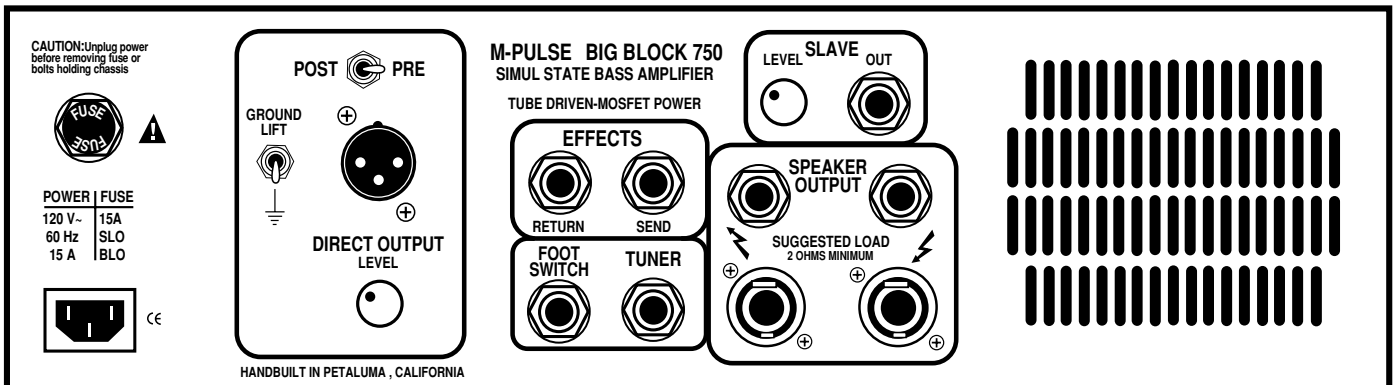

## Overview: *(Continued)*

Looking at the Front Panel, it is apparent how logically the controls are laid out before you, creating a simple and intuitive platform for expression. However, don't let this simplicity deceive you as to the incredible shaping power of this preamp. The tone controls are voiced such that minimal shaping is needed to achieve a warm musical blend, yet should you want to create your own signature sound, they can take you anywhere you wish to go quickly and effortlessly.

This tone control stack features two MID controls. A wide band passive MID works magically with the wide-band active BASS and TREBLE controls to create a balanced, spatial blend, while a semi-parametric MID allows frequency specific shaping over a wide range that covers low, mid and high mid/low treble frequencies. This array is simple to use, yet provides all the shaping power you will need while keeping the tweaking to an inspiring minimum.

In addition to this traditional gain stage, the **BIG BLOCK** features an all-tube overdrive stage with its own separate OVERDRIVE and MASTER controls. This footswitchable mode brings everything we've learned building high gain guitar amplifiers over three decades to focus on bass guitar and creates an incredible new frontier of truly usable overdriven bass sounds.

The Rear Panel neatly showcases all the features you would come to expect in a amplifier of this caliber and ensures all your interfacing needs are covered.

A balanced XLR DIRECT OUTPUT captures the entire preamp signal and features both PRE and POST options while its dedicated DIRECT LEVEL control allows you to match levels to all types of consoles. There is also a GROUND LIFT switch for the DIRECT circuit to help ensure a quiet signal when connecting to consoles that may have different ground references.

A dedicated TUNER circuit with both Front and Rear Panel Outputs features a footswitchable MUTE function for silent tuning when the footswitch is connected in stage or studio environments.

Outboard processing is handled through the series EFFECTS LOOP which is activated when cables are inserted into the SEND and RETURN jacks.

A SLAVE OUTPUT and dedicated LEVEL control are provided for capturing the entire sound of the preamp and power section. This is useful when another **BIG BLOCK** or additional power amplifiers are needed for large (coliseum size) venues. In this scenario the SLAVE is the perfect feed signal because it will pass on everything you do to the sound and give you control over the signal strength.

The **BIG BLOCK** delivers its massive power to the ground via the SPEAKER OUTPUT section which offers two types of jacks for cabinet interfacing. Standard jacks allow connection under any scenario with any cable, while the heavy duty NEUTRIK SPEAK-ON connectors lock the cable in place for speaker enclosures that incorporate this system as a design feature.

Finally, two punched grille vents serve as exhaust ports for the heat that is forced out of the two mosfet power blocks by the dual cooling fans. **NEVER BLOCK THESE VENTS!**

**NOTE: BLOCKING THE EXHAUST VENTS WILL CAUSE OVERHEATING AND LEAD TO INTERRUPTED PERFORMANCE OR EVEN DAMAGE TO YOUR AMPLIFIER.**

That wraps up the Overview, which has covered the controls and features briefly to familiarize you with the power and possibilities of the **BIG BLOCK 750**. Now let's get to each of the individual controls and see how they interact to create an individualized sound that is all yours.

## FRONT PANEL CONTROLS:

**INPUT:** This jack is the instrument **INPUT** which feeds the first tube in the all-tube preamp of the **BIG BLOCK**. It is set up with enough headroom to handle both passive and active style instruments. For active instruments you may find yourself running the **GAIN** control somewhere between 10:00 and 2:00 for optimum headroom. If you do hear a soft clip creeping in at higher settings, don't worry, this is the beauty of a tube front end. You may feel free to drive the preamp for a more furry character when hyper clean is just too clean.

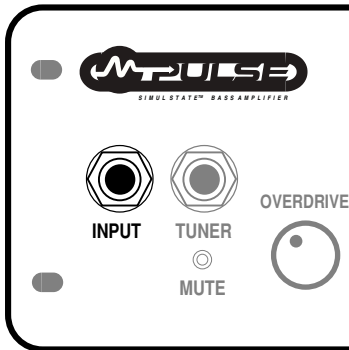

**NOTE:** When driving the preamp with higher settings of the **GAIN** control it is wise to reduce the **BASS** control and any low frequencies dialed up on the **ACTIVE MID** control. This will protect accidental damage to speakers and help avoid tubbiness or lack of tightness in the low end.

**TUNER:** This jack provides a convenient Front Panel output for connection of a **TUNER**. It is wired in parallel with the Rear Panel **TUNER** output. There is an optimum padded signal present at all times on both Front and Rear jacks. There is a **MUTE** function and LED indication, which is only controllable from the Footswitch. There is no mute function available when the Footswitch is disconnected.

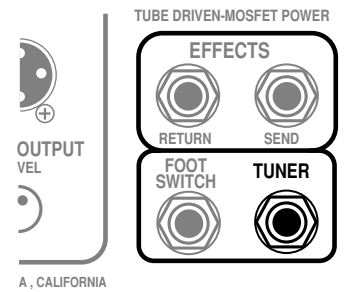
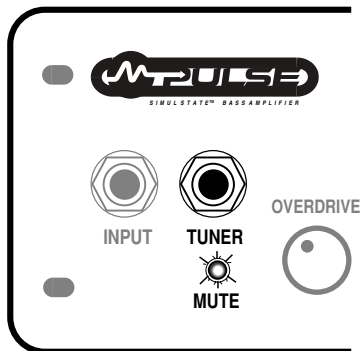

**OVERDRIVE:** This control determines the amount of all-tube **OVERDRIVE** that can be blended with the regular “clean” preamp signal. This circuit creates a whole new realm of sounds that range from a soft-clip purr, to fully saturated grind. The **OVERDRIVE** has been tailored specifically for bass applications and does not disturb the blend dialed up on the tone controls.



The **OVERDRIVE** circuit is activated via the included Footswitch and the combination of the Front Panel **OVERDRIVE** control (which determines the amount) and the O.D.MASTER (which gives you control over the volume of the **OVERDRIVE**), means that this feature creates a channel switching option that can be used for a wide range of choices.

In the lower region of the **OVERDRIVE** control, you will find that a subtle boost can create footswitchable soloing options where the added gain is merely thickening, rather than saturating the signal. Because this circuit has its own **MASTER** control, stepping out can be easy and controllable. You won't have to rely on band dynamics or house sound engineers to give you a little volume bump when you need it.

Setting the **OVERDRIVE** control above 12:00 reveals the higher gain potential of this circuit. Here a wide range of more obviously overdriven sounds appear that can be used to mimic an analog synth or provide the grinding aggression for an integral part in a heavy song. This range showcases how amazingly tight the overdrive tracks and makes this mode an essential part of the **BIG BLOCK'S** sonic power and magic.

## FRONT PANEL CONTROLS: (Continued)

**OVERDRIVE: (Continued)** Note that the **GAIN** control is still active when the **OVERDRIVE** is switched into the signal path. The **GAIN** control is wired in series with the **OVERDRIVE** and therefore, it can be used to further fine-tune the amount of overdrive present in the mix. The effect of the **GAIN** control is more apparent at the lower region of the **OVERDRIVE** control, where sweeping the **GAIN** is very noticeable. At higher **OVERDRIVE** settings it has a fairly diminished effect. Generally speaking, the sound will be brighter and more scooped in the mids at lower **GAIN** settings, while higher settings will produce a fuller, richer sound with less emphasis on upper harmonics.

We hope you find the **OVERDRIVE** mode a fun and musically expanding addition to an already amazing sounding preamp. Over time we believe you will come to find it an invaluable part of your sound.

**GAIN:** This control determines the overall character of the input sensitivity. The lower regions of the control (below 12:00) lend greater headroom and provide a scooped, brighter personality. The upper harmonics come through more prominently in this area of the control making the top end sound more transparent and sweet. This region is especially useful for funkier stuff when thumbing is in order. It keeps the rubber-band feel intact in the lows and mids while voicing the snap just high enough to avoid harshness, or the dreaded “gak” when the G string is plucked.

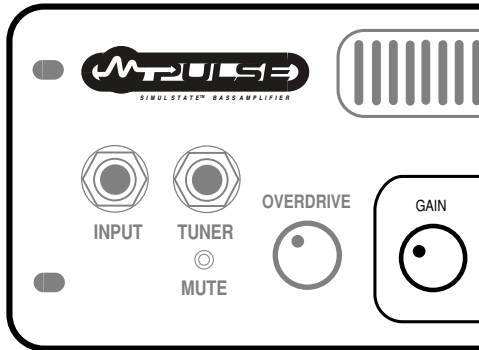

As the **GAIN** control is increased past 12:00 a richer, more “well-rounded” voice becomes dominant and headroom starts to diminish in increments until eventually, a tube overdrive sound appears as the 12AX7 input tube is driven into saturation.

The region between 12:00 and 2:30 is where the classic, warm tube sound resides and within this narrow band you will discover a world of tone. Tiny increments here produce subtle, but important differences in the attack characteristic which in turn, feel like changes in the time domain.

By experimenting with the amount of gain, you can actually voice the amp to feel as if it bounces just ahead of the groove - or lays back a little deeper to produce a more Fatback feel. The difference in attack and sustain produces striking results as to how the bassist - and in fact the whole band - perceives things in the time domain.

**BASS:** This control is responsible for the basic mix of low frequencies in the tube pre-amp. The **BASS** control is an active shelving type control as opposed to a passive style control. This means that a center Q point has been chosen and this control allows you to

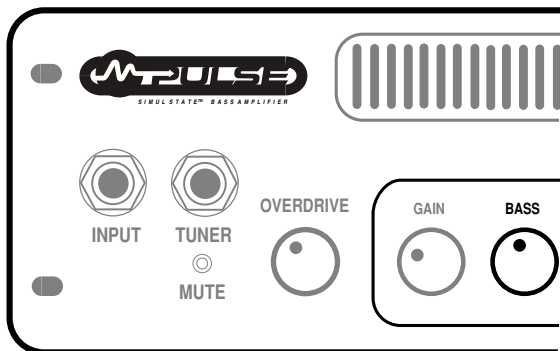

either boost or cut that frequency. This control differs from the low bands of the Parametric in that it has a broader Q point with a more gentle ramp as opposed to the Parametrics' narrow Q that is used with a separate **GAIN** control.

The **BASS** control is actually a gain and frequency control all rolled into one with the Q center at 55Hz and harmonics in both low and high directions are affected because of its broader band nature. As the control is increased past 12:00 there is a 6db per octave rise in gain with the frequency topping out at 321Hz. With 12:00 straight-up representing “flat” (a no boost/no cut setting). As the **BASS** control is dialed below 12:00, 55Hz and all associated harmonics are reduced and eventually notched completely out of the signal. Conversely, there is a 6db per octave cut beginning at 55Hz going down to 20Hz where the shelving ends with a *cut gain* of -20db as the control approaches 7:30 (off).

As the control is increased past 12:00 there is a 6db per octave rise in gain with the frequency topping out at 321Hz. With 12:00 straight-up representing “flat” (a no boost/no cut setting). As the **BASS** control is dialed below 12:00, 55Hz and all associated harmonics are reduced and eventually notched completely out of the signal. Conversely, there is a 6db per octave cut beginning at 55Hz going down to 20Hz where the shelving ends with a *cut gain* of -20db as the control approaches 7:30 (off).



## FRONT PANEL CONTROLS: (Continued)

**BASS: (Continued)** This type of broad band, active rotary control makes it possible to achieve bass characteristics far beyond that of a conventional passive type control. It can increase the low end to an almost absurd level and with a flick of the wrist, dip it to near transistor radio skinniness. Needless to say, with any control this powerful a certain amount of finesse must be applied to achieve musical results. Be especially mindful of this when using the 5 Band Parametric in conjunction with the **BASS** control.

**PASSIVE MID:** This is the only passive style control in the string of rotary tone controls. This scheme was chosen for its inherently musical blend and for the way the passive style midrange control, with its wide spread and smooth taper, *fills in the holes*.

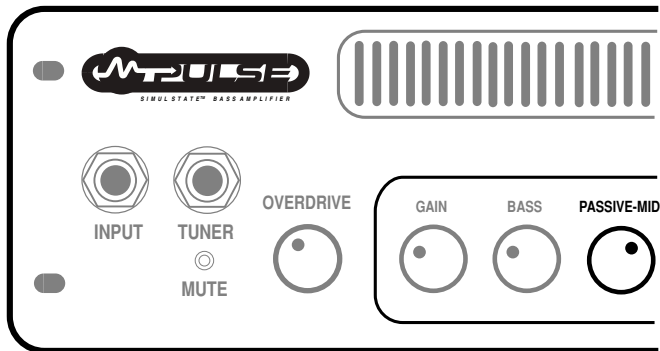

Unlike the BASS, this control is a **boost only**, and while it can competently remove this broad spectrum of midrange from the mix, it cannot provide the extreme attenuation of an active style control.

You will find, as we did, that this control works amazingly well for shaping the midrange frequencies with a natural earthiness and character that is a perfect counterpart to its neighbors. It is hard to dial wrong with this more forgiving control as it seems to give you just enough and no more.

For radical and specific scooping of the midrange frequencies for modern R&B and Funk styles, there is plenty of notching power that is infinitely more accurate to be found in the ACTIVE MID. Because of this, we opted for the tried and true passive style midrange control that has been working great in all of our amplifiers for decades. It's hard to improve on a classic.

**ACTIVE MID:** In addition to the passive style **MID** control, the **BIG BLOCK** features an **ACTIVE MID** circuit that allows further accentuation of specific midrange frequencies across a wide band. This wider band covers the spectrum from high bass/low mid all the way through to high mid/low treble frequencies.

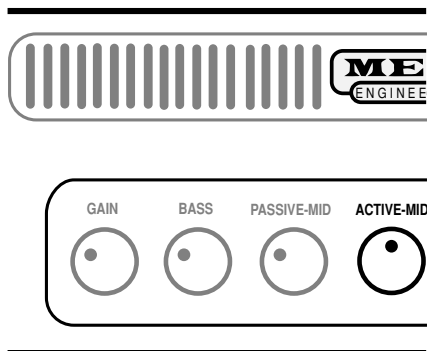

As you can see, this active circuit is made up of two controls; a **GAIN** control which is labeled **ACTIVE MID** that boosts and cuts the selected region, and a **FREQUENCY** control that allows selection of a specific range to manipulate. The **ACTIVE MID** is the gain or "amount" control. It provides 15db of gain in both plus (boost) and minus (cut) directions at the specific range selected on the **FREQUENCY** control.

Remember that this is a powerful control and that certain frequencies cut through (high mid/low treble) or seem especially loud (low mid/bass) so it is advisable to add gain with the **ACTIVE MID** control sparingly.

Set unwisely, this circuit is capable of creating sounds that are harsh, tubby or just simply unbalanced. This combined with the massive power available in the output section can spell real danger to speakers. We urge you to use this **ACTIVE MID** circuit with care and most of all taste, to avoid damage to your ears and speakers.

These two simple controls offer an incredible amount of shaping power in a simple to use format. When combined with the other tone controls, virtually any sound you desire is available to you quickly and with far less searching than when using multi-band equalizers. This simplicity is at the heart of the **BIG BLOCKS** character...great tone with minimal tweaking.

## FRONT PANEL CONTROLS: (Continued)

**FREQUENCY:** This control determines the frequency range that the ACTIVE MID control will cut or boost. As mentioned earlier, it covers a broad range that sweeps from the low midrange region to the lower treble frequencies. The control sweeps from 200Hz on the low side to 2Khz on the high side - with 340 Hz riding the center, straight up at 12:00 on the control. This sweepable band gives you pinpoint shaping power over the broad and usable midrange spectrum and also allows some overlap at the extreme ends of the control with the adjacent broad band BASS and TREBLE controls.



May we again remind you to use care and taste when dialing with this powerful control. Some frequencies stick out or cut more than others, making it possible to add unwanted, unpleasant and even dangerous, peaks or blow unbalanced holes in your sound. We suggest dialing in your sound with the standard tone control array first and then using the ACTIVE MID circuit to fine-tune and subtly enhance your sound.



**TREBLE:** The **TREBLE** is also an active shelving style control like that found in the BASS and again, it was chosen for its ability to radically shape the upper harmonic region. Like the BASS, it also has a center Q point with harmonics above and below responding in harmony as it is dialed for either cut or boost.



As the control is increased past 12:00, it produces a 6db per octave rise in gain starting at 723Hz until +20db is reached. From this point, gain remains constant at +20db for all frequencies above 723Hz all the way out to 20Khz. This scheme lends a sweetness of sound while retaining all the necessary cut and focus associated with a traditional passive **TREBLE** control. As this control is dialed below 12:00, it begins a 6db per octave cut from 3.2Khz to the shelving point at 723Hz, where it continues to attenuate all frequencies above 723Hz until - 20db is reached where *cut gain* remains constant until the control reaches 7:30 (off). The ability to cut these frequencies more radically makes it possible to obtain incredibly rich and warm old-school R&B and Jazz sounds that rival any recordings of the day.



This active shelving **TREBLE** control completes the rotary tone control string to create a powerful and extremely accurate network to use as your fundamental platform. It's no wonder many first time **BIG BLOCK 750** players make the comment that just these controls combined with the GAIN create the best tone they have ever heard!

**NOTE:** As with the BASS control, may we remind you that a control of this type with its increased power should be used with finesse. In the **TREBLE'S** case, almost more so, because higher frequencies seem louder to the ear and are generally more painful when set to extremes. Another reason to use care is that high frequencies tend to increase the ambient noise floor when set too high. This is then exacerbated if the 5 Band Parametric is combined for added top end boost. Dial with care and music in mind.

**MASTER:** The **MASTER** control is the feed to the *Simul State* power section and determines the overall playing volume of the **BIG BLOCK 750**. An optimum setting will be determined by the setting of the GAIN control as well as the entire tone control network. All these controls affect the signal strength at the end of the preamp and can make the **MASTER** control very sensitive.

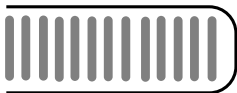

**NOTE:** Remember to use with caution as the **MASTER** is the gas pedal for the massive power available. We suggest a zero setting at each power up to avoid damage to speakers and ears.

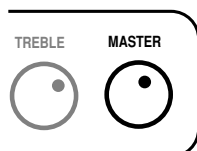

## FRONT PANEL CONTROLS: (Continued)

**O.D. MASTER:** This control, like the OVERDRIVE, is designed to help you think outside the box. It provides an independent volume control for the OVERDRIVE mode, allowing you to preset the level of the overdriven sound and footswitch to it for specific parts.

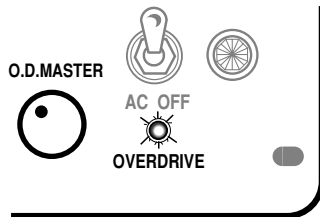

The **O.D. MASTER** is only active when the Footswitch is connected to the Rear Panel FOOTSWITCH jack. This control gets its feed from the OVERDRIVE, GAIN and entire Tone Control Array and allows you to either increase or decrease the playing volume relative to the Clean (normal) mode.

This is especially important because overdriven sounds are more compressed than clean sounds and as greater amounts of overdrive are added, it will compress the signal more, making the relative volume to the normal mode seem lower.

**NOTE:** The OVERDRIVE LED will illuminate when the OVERDRIVE mode is activated with the Footswitch indicating that both the OVERDRIVE and O.D. MASTER are in the signal path and active.

**POWER SWITCH:** This switch delivers the A.C. power to the **BIG BLOCK 750**. Make sure the unit is grounded (all three terminals of the A.C. power cord must be connected whenever possible to avoid injury to the user as well as to the amplifier). Also, make sure that the proper voltage requirements are present at the A.C. wall socket receptacle.

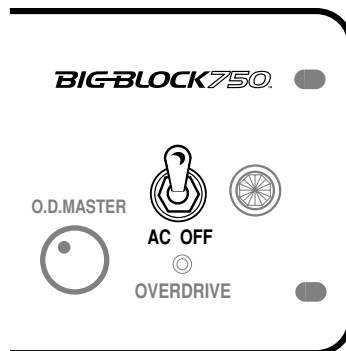

**NOTE:** As a reminder, never alter the A.C. power cord in anyway for possible damage to the amplifier may occur not to mention the possibility of a fire outbreak.

Now that we have reviewed the features and controls on the Front Panel, let's take a spin around back and review the interfacing connections.

## REST AREA

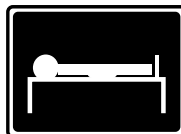
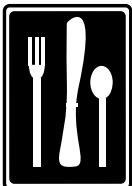

# REAR PANEL CONTROLS:

## REAR VIEW: Big Block 750

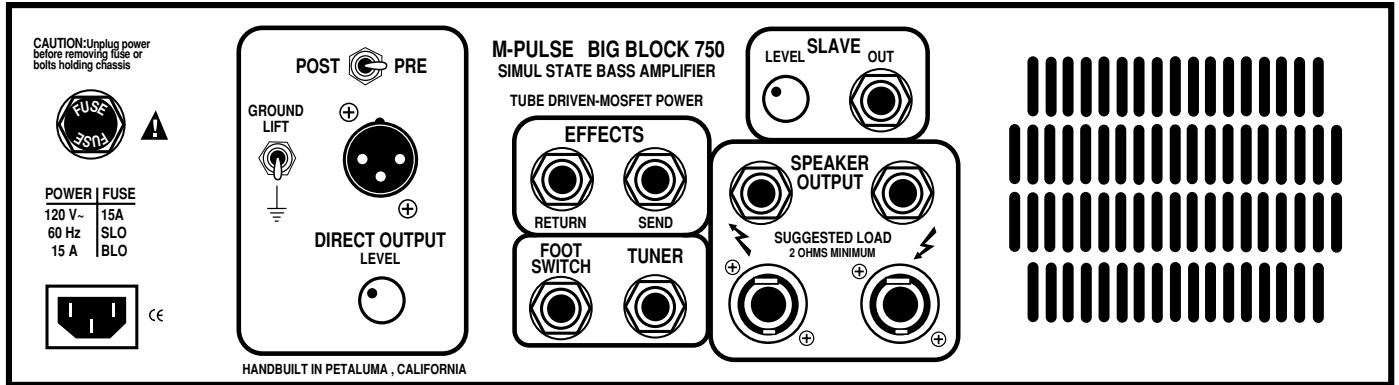

**FUSE:** This is the A.C. Mains Fuse for the **BIG BLOCK 750**. REPLACE ONLY WITH A SLO-BLO TYPE FUSE OF THE PROPER RATING. THIS IS EXTREMELY IMPORTANT, AS THE **BIG BLOCK 750** DRAWS A SUBSTANTIAL AMOUNT OF CURRENT AT HIGH OUTPUT LEVEL SETTINGS.



FUSE rating for USA - 15A S.B. / 120 Volts.FUSE

**AC RECEPTACLE:** The removable "Euro" Style A.C. cord that is supplied with the **BIG BLOCK 750** makes set-ups and tear-downs after the gig a snap. It also makes de-racking much easier when you wish to remove the unit from a hard wired rack system where all the A.C. cords have been cabled in. Additional heavy duty cords are available should you ever need one...simply call us direct and we can ship one directly to you for a nominal charge, plus shipping cost. Make sure the A.C. cord is firmly in its socket (receptacle) before powering up the amplifier.

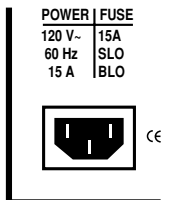

**NOTE: NEVER ALTER THE THREE PRONG POWER CORD IN ANY WAY.**

**GROUND LIFT / POST & PRE / DIRECT OUT:** This section captures the entire pre-amp signal including the Parametric EQ, the Compressor and the Effects Loop and allows you to send a Balanced signal to either a House Main Board or a Recording console. There are four elements to this circuit which are; (1) a male XLR jack, (2) a LEVEL control, (3) a POST / PRE switch and (4) a GROUND LIFT switch. Here are their functions and how to use them.

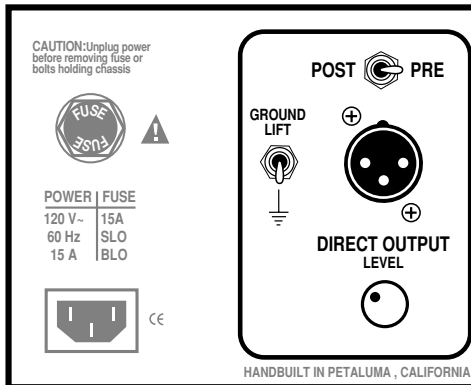

**LEVEL:** This rotary control allows you to set an appropriate level for the Direct Signal to match the input sensitivity of the console. It is always best to start with the LEVEL control zeroed-out before connecting a cable to the DIRECT output. This practice will help to avoid accidental damage to the speakers or your engineers' ears from too hot a setting upon hitting your first note.

**POST / PRE:** This switch lets you choose the type of signal you wish to send to the console. **POST** gives you the entire sound of the pre-amp with the Parametric EQ, Compressor and the Effects Loop (including processing from anything in the loop).

## REAR PANEL CONTROLS: (Continued)

**GROUND LIFT / POST & PRE / DIRECT OUT: (Continued)** **PRE** gives you just the sound of your instrument and no **BIG BLOCK 750** enhancement so that an engineer can create their own sound with your unprocessed signal at the console. This is very handy for sound reinforcement applications as the sound you use on stage may be too big with enhanced low end for a large venue house application.

**GROUND LIFT:** This switch removes the circuit-to-chassis ground connection from the XLR jack. Leave it in the grounded position (switch down) normally unless you experience a hum when connecting to a console. If you do experience a hum when connecting the XLR Output to a console, try lifting the ground (switch up) on the circuit. This will usually (but not always) remedy most ground loop type noise from the signal path. Sometimes it may also be necessary to lift the A.C. Cable Ground also by using a 3-2 ground adapter to achieve a quiet signal path.

**NOTE:** Ground loops can occur in many places in a complex signal path. The **DIRECT OUTPUT GROUND LIFT** switch is not a cure-all and therefore should not be expected to remedy every type of ground related problem.

**EFFECTS:** These two jacks provide an interface for external signal processors and they access a point between the preamp and power section. This wiring scheme creates a Series Effects Loop that is well matched to the input and output impedance of most good quality processing devices. The jacks used in the loop are switching-type jacks - meaning that when nothing is inserted into either **SEND** or **RETURN** the preamp signal bypasses the jacks. When cables are inserted the signal path is interrupted and sent through the **EFFECTS LOOP**.

M-PULSE BIG BLOCK 750  
SIMUL STATE BASS AMPLIFIER  
TUBE DRIVEN-MOSFET POWER

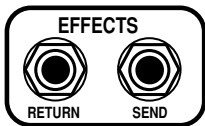

Because the loop is wired in series, anything you do to the signal here will affect the entire sound of the amplifier. Therefore we suggest using only the highest possible quality of processing devices and the best possible low capacitance cables of the shortest possible length.

**NOTE:** Cable lengths of 1 foot are best with 3 feet being about the longest desirable length. Using longer interface cables in the series loop will introduce unwanted capacitance and begin to roll off top end and attack.

### To use the EFFECTS LOOP;

- 1 ) Connect the SEND jack to your processors' INPUT.
- 2 ) Connect the RETURN jack to your processors' OUTPUT.
- 3 ) Adjust the dry/wet blend with your processors' MIX ( WET OUTPUT ) control.

**FOOTSWITCH:** This 1/4" stereo jack accepts the stereo phone plug from the included **BIG BLOCK** Footswitch. Connecting the **FOOTSWITCH** via this jack allows remote activation of the **OVERDRIVE** and **SOLO** features.

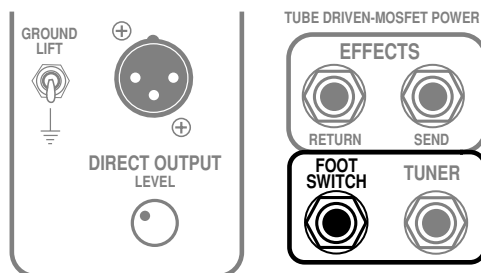

HANDBUILT IN PETALUMA , CALIFORNIA

These two features can only be activated when the **FOOTSWITCH** is connected. The Front Panel controls for these features are bypassed when the **FOOTSWITCH** is disconnected.

## REAR PANEL CONTROLS: (Continued)

**TUNER:** This Rear Panel auxiliary **TUNER** output is wired in parallel with the Front Panel **TUNER** output. This provides for Rear Panel interfacing of rack mount tuners, where it is preferable to have all wiring stay in the rear of a rack system.



The Footcontroller MUTE switch activates the MUTE feature in both Front and Rear outputs simultaneously.

**SLAVE:** The **SLAVE** feature provides a padded signal that is derived from the Speaker Output and captures the entire sound of the preamp and power section. This is useful for large venue applications, where multiple **BIG BLOCK** or other slave amplifiers are strung together for additional power to drive more speaker enclosures.

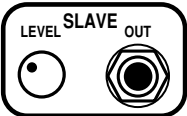

The **SLAVE** may also be used as a send signal to feed outboard processing racks in a dry/ wet setup where processing is done after the **BIG BLOCK 750** and then fed to a Stereo power amplifier for separate control of the wet sound. This works very well and is similar to what is done in the recording environment where a dry signal is blended with another channel on the console that is only the processed (wet) version of the same sound.

**NOTE:** Once a signal has been taken from the **SLAVE**, you can not feed the signal back into the **BIG BLOCK** Effects RETURN jack or INPUT. Doing so will cause a feedback loop resulting in a high pitched squeal, much like a microphone held up to a monitor. You must go into an external amplifier or device once a signal has been taken from the **SLAVE**.

**NOTE:** Always start with the **SLAVE LEVEL** at 7:00 (off) and increase the level slowly to prevent damage to ears, speakers and the input stage of external processors.

**NOTE:** The **SLAVE** is not optimized for direct interfacing into recording consoles or live mixing boards. For this application it is best to use the **DIRECT OUT**.

**SPEAKERS:** These two sets of outputs are responsible for delivering the mighty power of the **BIG BLOCK** to your speaker enclosure(s) of choice. We would like to suggest that if you have not already auditioned one of our many incredible new Bass Enclosures, that you do so at your earliest convenience. They have been designed to deliver the ultimate tone and maximum power from your amplifier and we feel confident that like us, upon hearing them, you will find the competition disappointing.

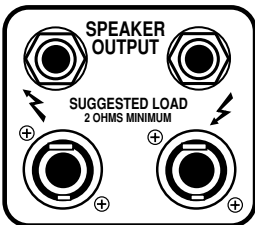

Two styles of speaker connectors have been provided so that any type of cabinet configuration may be interfaced with the **BIG BLOCK** NEUTRIK brand "SPEAK-ON" Connectors provide for locking 1/4" interfacing and all **MESA** Bass Enclosures will come standard with these additional heavy duty jacks. In addition the standard 1/4" phone jacks are also supplied for older cabinetry that does not support these "SPEAK-ON" connectors.

Your **BIG BLOCK** was designed so that it will deliver its maximum power (750 watts RMS) at an impedance load of 2 Ohms and it can do so without worry of overheating. However, feel free to use any combination of cabinets with a combined load above that impedance with no worry of damage to the amplifier. At higher impedance loads (4 or 8 Ohms) overall power will be diminished, but this works out in your cabinets favor as some cabinets may not be rated to take the full assault of the awesome power available in the **BIG BLOCK** output section.

**NOTE:** It is possible to use the **DIRECT OUT** for recording direct to consoles with no load present (no Speaker cabinet connected) on the **SPEAKER OUTPUT** without worry of damaging the amplifier.

That covers the features of the **BIG BLOCK** Rear Panel, and now with the combined understanding of the controls, you should be able to dial with confidence as you search for your signature sound. We wish you many years of inspiration and musical fulfillment from your new amplifier. From the entire **MESA** Family, **CHEERS!**

# FACTORY SAMPLE SETTINGS

## SAMPLE SET #1: Round Warm R & B

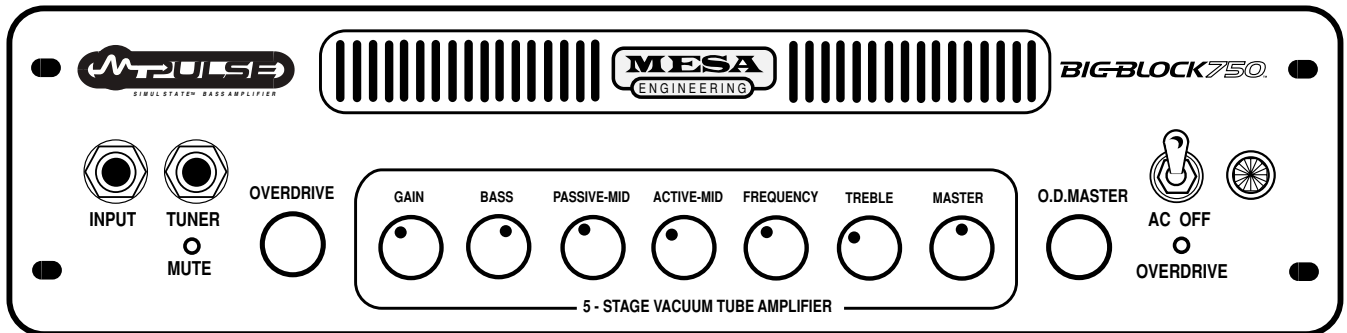

## SAMPLE SET #2: Scoopy Slap

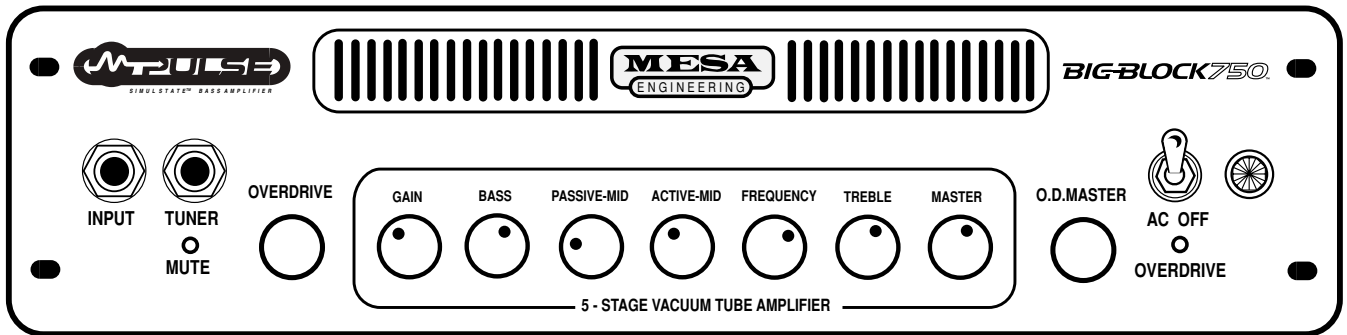

## SAMPLE SET #3 Purring Edge

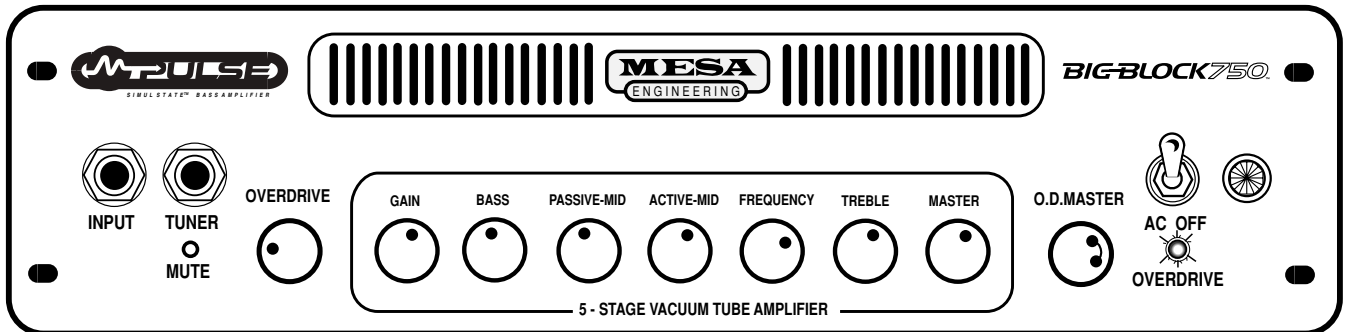

## SAMPLE SET #4: Overdrive Solo

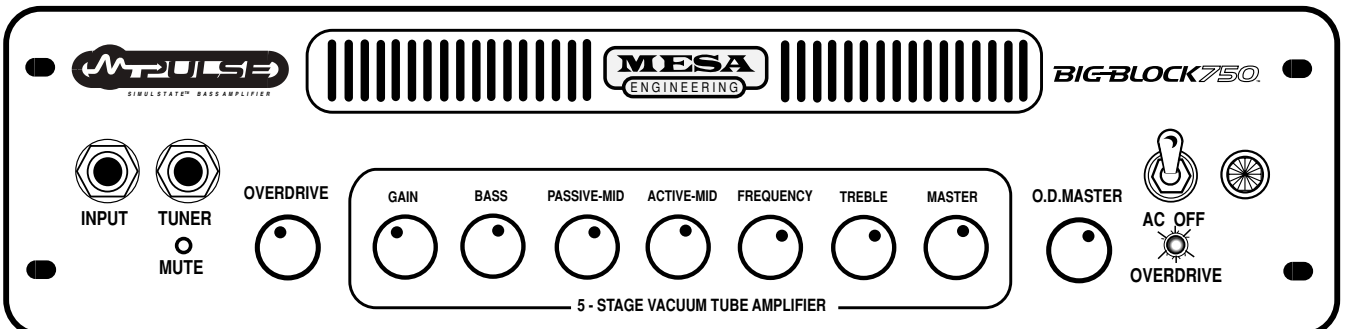

# PERSONAL SETTINGS SHEET

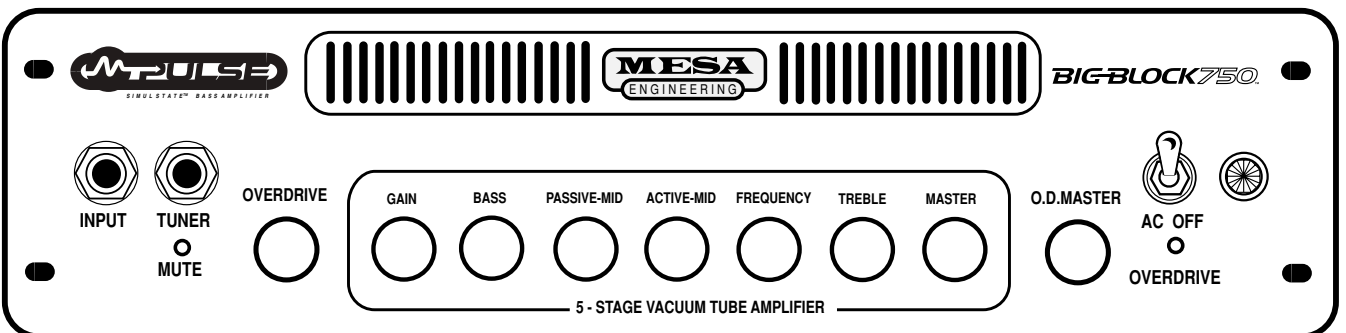
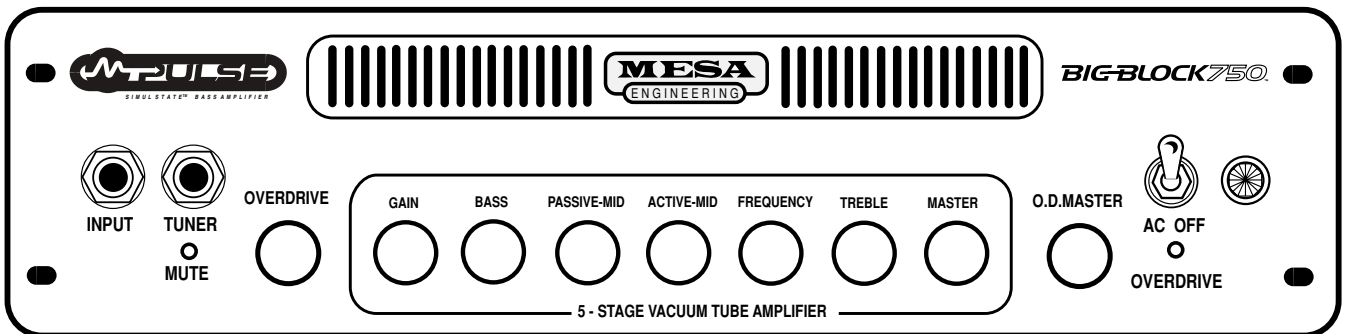
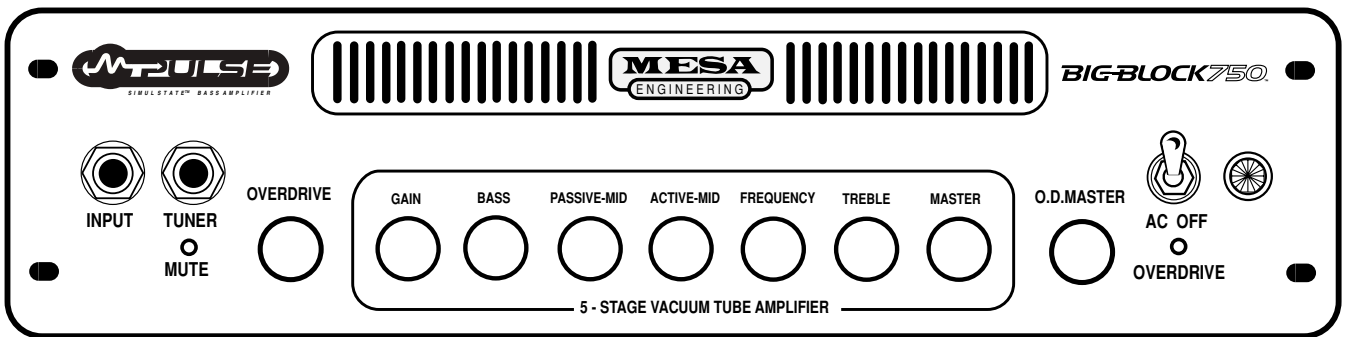
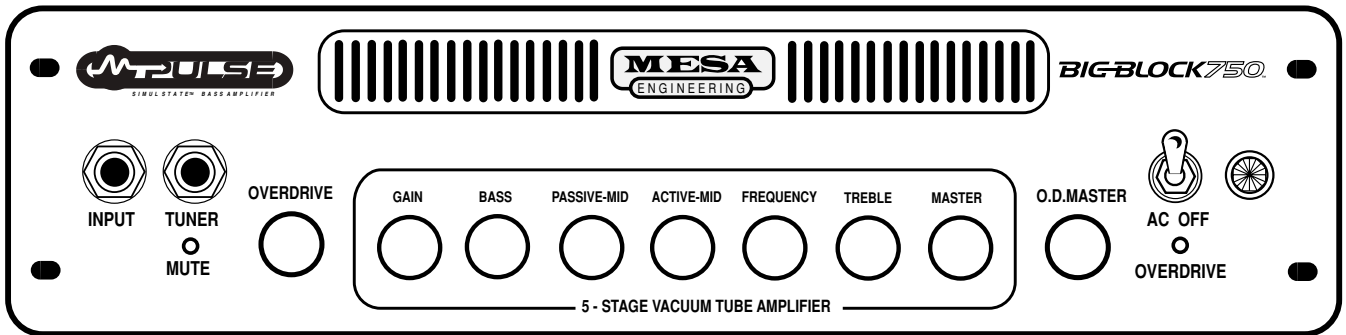



## **DIAGNOSING PREAMP TUBE PROBLEMS:**

At some point it is quite possible that you will experience some kind of minor pre-amp tube noise. Rest assured - this is no cause for alarm and you can take care of the problem yourself in a matter of minutes by simply swapping tubes. It is always a good idea to keep at least a couple of spare pre-amp tubes on hand at all times to insure uninterrupted performance. These minor pre-amp tube problems can take many forms but can generally be described in two categories: Noise and Microphonics. Noise can be in the form of crackling, sputtering, white noise/hiss and/or hum. Microphonic problems usually appear in the form of a ringing or high pitched squealing that gets worse as the gain or volume is increased thus are more noticeable in the higher gain "HI" modes. Microphonic problems are easily identified because the problem is still present even with the instruments' volume off or unplugged altogether - unlike pick-up feedback which ceases as the instrument is turned down. Microphonic noise is caused by mechanical vibration and shock: think of banging a microphone around and you'll understand where the word came from.

The best way to approach a pre-amp tube problem is to see if it occurs only in one specific mode or channel. This should lead you to the tube needing replacement. If you cannot narrow down the trouble to a specific mode or channel, the problem may be the small tube that drives the power tubes which is operational in all modes and channels. Though rare, a problem with the driver tube would show up in all aspects of performance - so if you can't narrow the problem down to being mode or channel specific, you may want to try replacing the driver tube. Driver problems generally show themselves in the form of crackling or hum in all modes of performance and/or weak overall output from the amplifier.

**NOTE:** When removing a tube from its socket, grasp tube near the top and rock gently from side to side while simultaneously pulling upward.

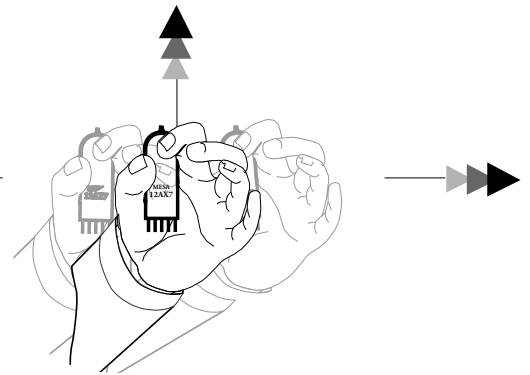

Sometimes making the diagnosis is more trouble than it's worth and it's faster and easier to merely replace the small pre-amp tubes ONE AT A TIME with a replacement known to be good. But MAKE SURE you keep returning the tubes to their original socket until you hit the one that cures the problem. You'll notice that tubes located nearer to the INPUT jack always sound noisier...but this is because they are at the start of the chain and their noise gets amplified over and over by the tubes that follow. The tube that goes into this "input socket" (usually labeled V1) needs to be the least noisy of the bunch. The tube that goes at the end of the preamp chain - just ahead of the power tubes - can be quite noisy without causing any problem at all. The tubes in your amp have already been located in the most appropriate sockets and this is why you should NEVER pull them all out at once and ALWAYS swap them one at a time. ALWAYS return a perfectly good tube to its original socket. Also it's a good idea to put the amp on STANDBY when swapping tubes to reduce the heat build up in the tubes themselves and to prevent explosive noises (which can still occur even if you are pulling the tubes away from their sockets gently) from coming through the speaker.

To wrap the chassis, use plenty of tightly wadded up newspaper so there is at least six inches of "crush space" between the chassis and the cardboard box. Bubble wrap also works well, but please DON'T use styrene peanuts - they will shift during transit and get lodged inside your electronics as well as allowing your amp to end up at the bottom of the box unprotected and possibly damaged. Pre-amp tubes don't normally wear out as a rule. Therefore, it is not a good idea to change them just for the sake of changing them. If there isn't a problem - don't fix it. If there is no result from your substitutions, it may be possible that you have more than one problematic tube. Though rare, this does happen and though it makes the troubleshooting process a little more intimidating, it is still possible to cure the problem yourself.

**NOTE:** It is normal to hear a slight metallic ringing sound when tapping on the preamp tubes. As long as the tube does not break into oscillation or start crackling or any other form of bizarre noise, it is considered normal and functional.

**FRONT VIEW: Big Block 750**

ALL FRONT PANEL KNOBS SAME  
part # 408114

SWITCH  
pt# 600631

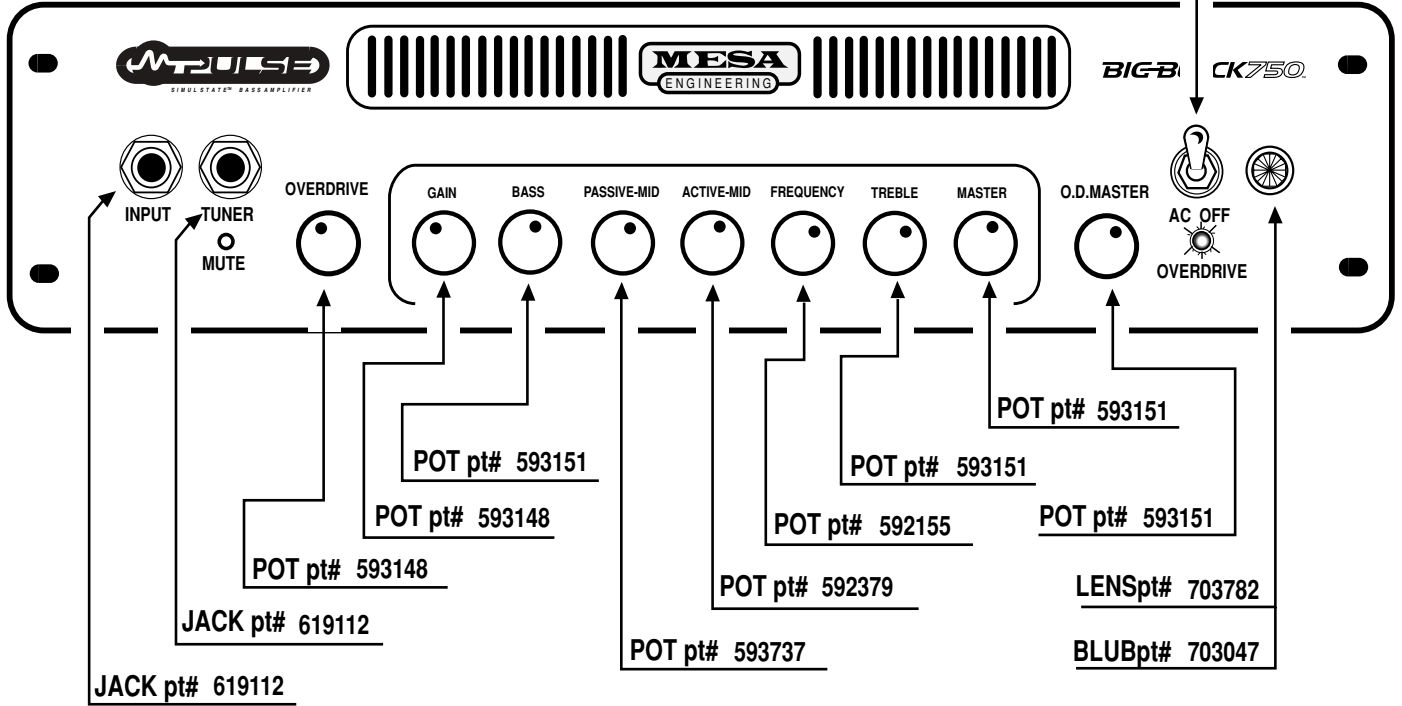

**REAR VIEW: Big Block 750**

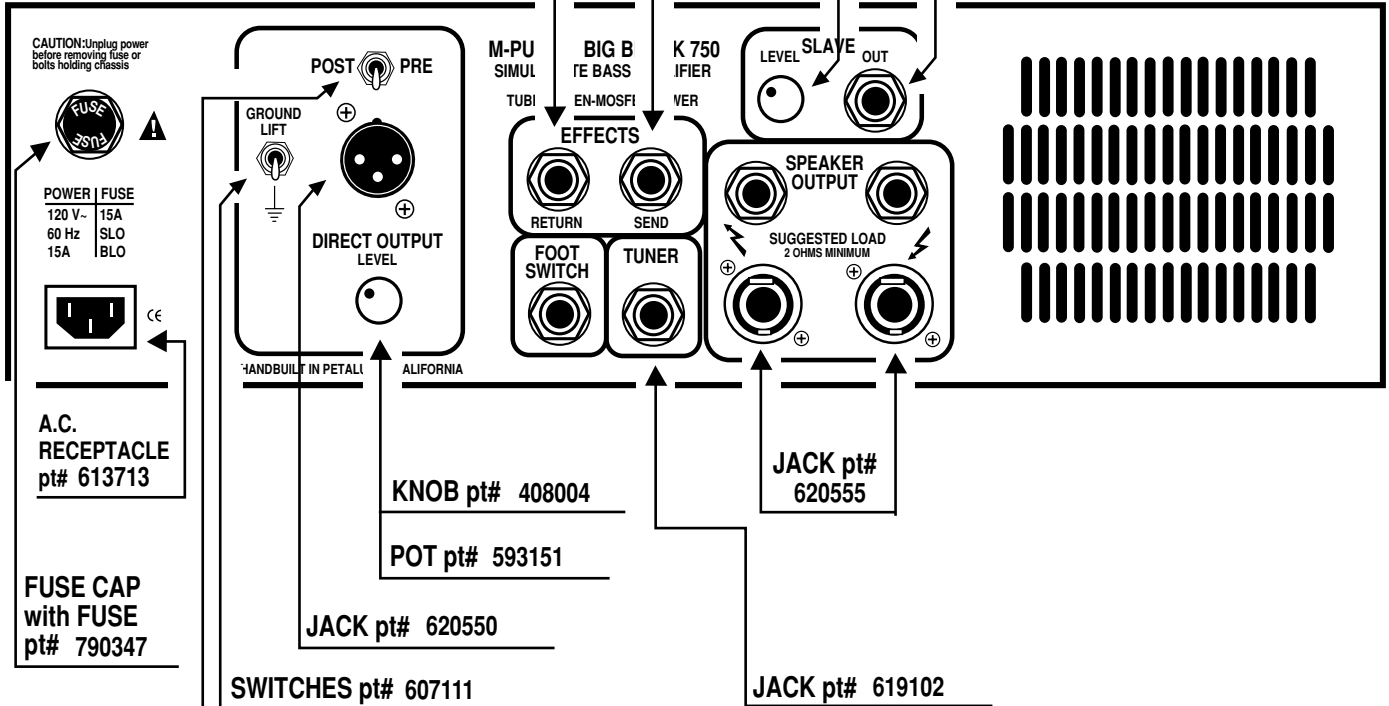

# ***MESA/BOOGIE***

*The Spirit of Art in Technology*

*Thank you for trusting MESA/Boogie to be your amplifier company and we wish you many years of toneful enjoyment from this handbuilt all tube instrument.*

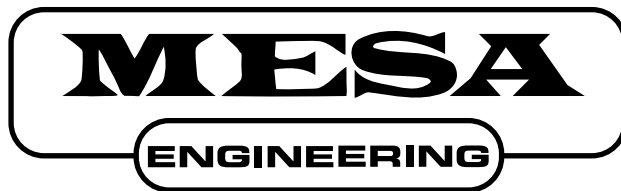

*The Spirit of Art in Technology*



*(707) 778-6565      FAX NO. (707) 765-1503*

*1317 Ross Street Petaluma, CA 94954*

*USA*